



C 11 M



C 11 M_ 1200 Kg



www.ausa.com

MAST CHART					
Type	Maximum lifting height (mm)	Free lift (mm)	Mast height retracted (mm)	Max. height (mm)	Load (Kg)
Duplex Free lift	2500	1270	1890	3140	920
Duplex (st)	2660	70	1980	3310	1200
Duplex	3300	120	2300	3950	1100

DIMENSIONES (mm)	
C 11 M	
A	1900/2040*
B	240
C	225
D	1280
E	1240
F	3250
G	2540
I	100
J	35
K	470
L	3515
M	315
N	1730
O	1000
P	4900
Q	13
R	5

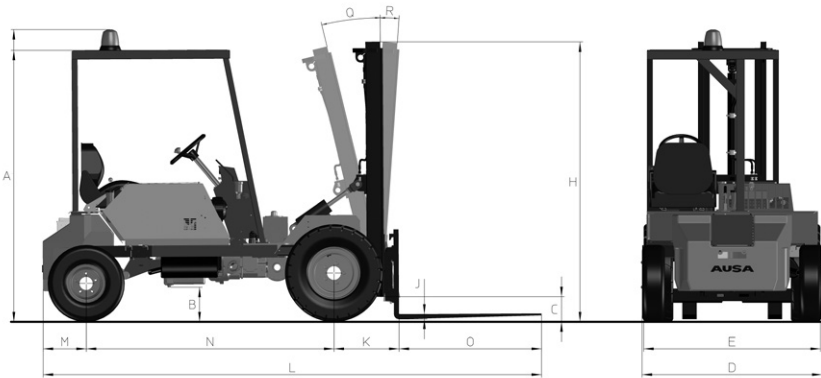

TECHNICAL SPECIFICATIONS

		C 11 M
Load capacity (kg) @ centre of gravity		1200 @ 500 mm / 1090 @ 600 mm
Lifting height (Standard duplex mast) (mm)		2660
Engine	Diesel	KUBOTA D902
	Power acc. (KW/HP)	12 / 16
	Nº of cylinders	3
	Cooling system	Water
Traction		4 x 2
Transmission		Mechanical, with semi-synchronised gearbox, with 4 forward gears and 4 reverse.
Engine starting system		Electric
Speed (Maximum) (Km/h)		20
Unladen weight (Kg) (with full tanks)		2160
Gradeability		35%
Hydraulic circuit		14.6 cc gear pump. Working pressure 180 bar.
Tyres	Front	7.00-12
	Rear	6.00-9
External turning radius (mm)		3250
Steering		Hydraulic with priority valve. Working pressure 100 bar.
Tank capacity (l)	Fuel	25
	Hydraulic fluid	15
Service brake		Hydraulic, drum-type, on front axle
Parking brake		Mechanical on front axle
Forkcarriage		FEM 2 - Width: 1260 mm
STANDARD EQUIPMENT		Ergonomic seat with seat belt Protective roof (ISO 6055). Rear view mirror. Rotating beacon. Audible reverse warning Side-shift: 1260 mm (width).
OPTIONAL EQUIPMENT		Homologated lighting equipment. Work headlights, two front and one rear Load backrest: 1250 mm. 2.50 m duplex mast with free lifting up to 1.20 m with integrated side-shift (Mast retracted height = Machine height 1,89m) Forks 1.200 mm Hydraulic buckets: 400 l.
Tyres	Front	27x10-12
	Rear	21x8-9

AUSA reserves the right to make any changes in the specifications without prior notice.